

UNI-Top Circular Saw Blades

One blade for any job

Tooth shape:

Alternating tooth (AT) with small angle of +5°.

Application:

The universal circular saw blade for the construction site; makes clean cuts in the widest variety of materials.

Machine:

Hand-held circular saws, mitre saws, panel saws and table circular saws.

Materials:

Hard and soft woods, particle boards (raw, coated, veneered), cover boards, plastics, composites and non-ferrous metals (aluminium, copper and brass).

Dimensions in mm (dia. x thickness x hole)	No. of teeth	Max. rpm	Aux. holes	RR* mm	Art. No.	P. Qty.
150 x 2.8/1.8 x 20	24 AT	10,200	-	16	0611 615 024	1
160 x 2.8/1.8 x 20	24 AT	9,500	-	16	0611 616 024	
170 x 2.8/1.8 x 30	24 AT	9,000	-	20	0611 617 024	
180 x 2.8/1.8 x 30	30 AT	8,500	-	20	0611 618 030	
190 x 2.8/1.8 x 30	30 AT	8,000	-	-	0611 619 030	
200 x 2.8/1.8 x 30	30 AT	7,600	-	-	0611 620 030	
210 x 2.8/1.8 x 30	34 AT	7,300	-	-	0611 621 034	
230 x 2.8/1.8 x 30	34 AT	6,600	-	-	0611 623 034	
235 x 2.8/1.8 x 30	34 AT	6,600	-	-	0611 623 534	
240 x 2.8/1.8 x 30	42 AT	6,400	-	-	0611 624 042	
250 x 3.0/2.0 x 30	42 AT	6,100	Combo (2/7/42 - 2/9/46 - 2/10/60)	-	0611 625 042	
300 x 3.2/2.2 x 30	48 AT	5,100	Combo (2/7/42 - 2/9/46 - 2/10/60)	-	0611 630 048	
300 x 2.4/2.0 x 25.4	60 AT	5,100	Combo (2/7/42 - 2/9/46 - 2/10/60)	-	0611 630 061	
350 x 3.2/2.2 x 30	54 AT	4,400	Combo (2/7/42 - 2/9/46 - 2/10/60)	-	0611 635 054	
400 x 3.5/2.5 x 30	60 AT	3,800	Combo (2/7/42 - 2/9/46 - 2/10/60)	-	0611 640 060	
450 x 3.5/2.5 x 30	66 AT	3,400	Combo (2/7/42 - 2/9/46 - 2/10/60)	-	0611 645 066	

* Reduction ring included

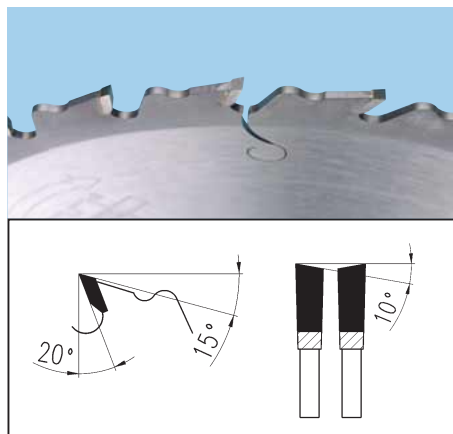

Blank Circular Saw Blades

For quick cutting when separating and blocking wood

Tooth shape:

Alternating tooth (AT).

Application:

For lengthwise and cross cuts.

Machine:

On table circular saws.

Materials:

Hard and soft woods.

Design:

Chip thickness limitation via deflectors.

Dimensions in mm (dia. x thickness x hole)	No. of teeth	Max. rpm	Aux. holes	Art. No.	P. Qty.
250 x 3.2/2.2 x 30	24 AT	6,100	Combo (2/7/42 - 2/9/46 - 2/10/60)	0611 025 241	1
300 x 3.2/2.2 x 30	28 AT	5,100	Combo (2/7/42 - 2/9/46 - 2/10/60)	0611 030 281	
315 x 3.2/2.2 x 30	28 AT	4,800	Combo (2/7/42 - 2/9/46 - 2/10/60)	0611 031 281	
350 x 3.5/2.5 x 30	32 AT	4,400	Combo (2/7/42 - 2/9/46 - 2/10/60)	0611 035 321	
400 x 3.5/2.5 x 30	36 AT	3,800	Combo (2/7/42 - 2/9/46 - 2/10/60)	0611 040 361	
450 x 4.0/2.8 x 30	32 AT	3,400	Combo (2/7/42 - 2/9/46 - 2/10/60)	0611 045 321	

Reduction rings for Circular Saw Blades

Outer diameter in mm	Inner diameter in mm	Thickness in mm	Art. No.	P. Qty.
20	16	1.6	0611 861 106	1
	15		0611 861 107	
30	20	1.8	0611 861 113	
	25		0611 861 116	

Note

Auxiliary hole 2/7/42 for Striebig/Reich machines.
Auxiliary hole 2/9/46 for Felder and Italian machine manufactures.
Auxiliary hole 2/10/60 for Martin, Kölle, Altendorf and Panhans.