

COMBINATION SPANNER

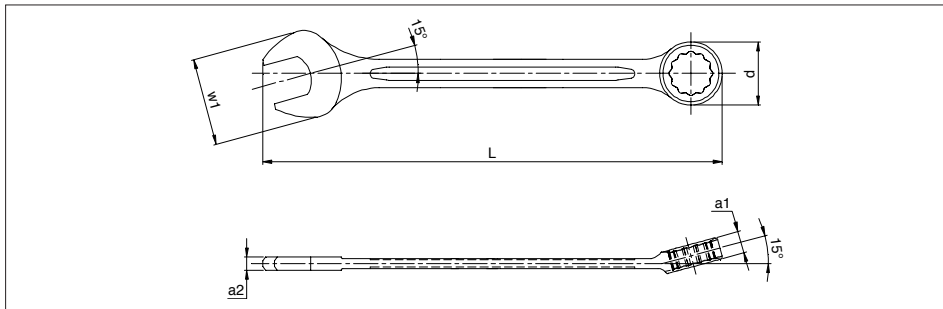

RED LINE



Version: metric, short design

- Drive: Ring side double hexagon
- Standard: DIN 3113 / DIN 475-2
- Material: Chrome-vanadium-steel
- Surface: Chrome matt plated, open end polished
- Geometry: Ring side 15° angled down, openend position 15°

The bihexagon on the ring side and the 15° open-end position are optimal in relation to the handle, resulting in a minimal angle of rotation.

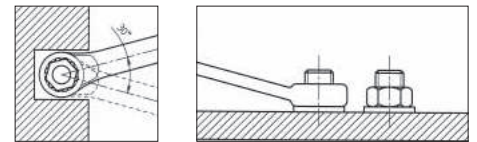

The 15° angle of the ring wrench enables more space for fingers or for overcoming obstacles.

	L mm	W1 mm	dia. D mm	a1 mm	a2 mm	Art.	P. Qty.
6	100	16	10.4	4.8	3.4	5754 301 06	1/100
7	110	16.8	11.8	5.4	3.5	5754 301 07	
8	115	18.7	13	5.6	3.8	5754 301 08	
9	125	20.6	14.1	6	4	5754 301 09	
10	135	22.4	16	6.3	4.5	5754 301 10	
11	145	24	17.2	6.8	4.9	5754 301 11	1/50
12	155	26.3	18.5	7.2	5	5754 301 12	
13	165	28.3	19.8	8.3	5.6	5754 301 13	
14	171	30	21.2	8.5	5.7	5754 301 14	
15	185	31.9	22.6	9.2	6.1	5754 301 15	
16	195	34	24.1	9.3	6.5	5754 301 16	1/10
17	210	35.2	25.3	9.6	6.8	5754 301 17	
18	220	37.5	27.2	10.1	7.2	5754 301 18	
19	230	39.7	28.4	10.2	7.3	5754 301 19	
20	240	41.4	29.5	10.8	7.4	5754 301 20	
21	245	43.2	31.4	11.1	7.6	5754 301 21	1/5
22	248	45.3	32.4	11.7	7.9	5754 301 22	
23	260	47.5	34.8	12.2	8.1	5754 301 23	
24	270	49.5	35.5	12.8	8.4	5754 301 24	
25	282	51	36.4	13	8.7	5754 301 25	
26	290	53.5	37.9	13.3	9.1	5754 301 26	1/5
27	300	54.8	39.4	13.9	9.1	5754 301 27	
28	310	56.8	42	14.8	9.7	5754 301 28	
29	330	60.1	43.2	15.2	9.9	5754 301 29	
30	330	60.1	43.2	15.2	9.9	5754 301 30	
32	350	64	46.5	15.9	10.2	5754 301 32	1/5
34	380	71.4	50.3	16.6	11	5754 301 34	
36	400	76.7	52.8	19.3	11.6	5754 301 36	

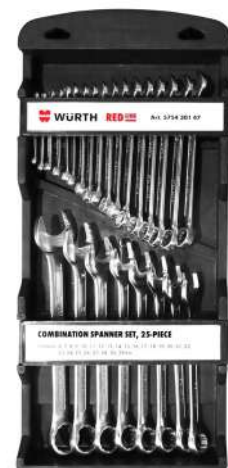

Set		Art.	P. Qty.
12 pcs	6,7,8,9,10,11,12,13,14,17,19,22	5754 301 460	1
17 pcs	6,7,8,9,10,11,12,13,14,15,16,17,18,19,20,21,22	5754 301 41	1
25 pcs	6,7,8,9,10,11,12,13,14,15,16,17,18,19,20,21,22,27,28,30,32	5754 301 47	1